

# Submittal

## Single Packaged Convertible Gas/Electric 14 SEER

4YCC4036A1070A  
4YCC4036A1090A

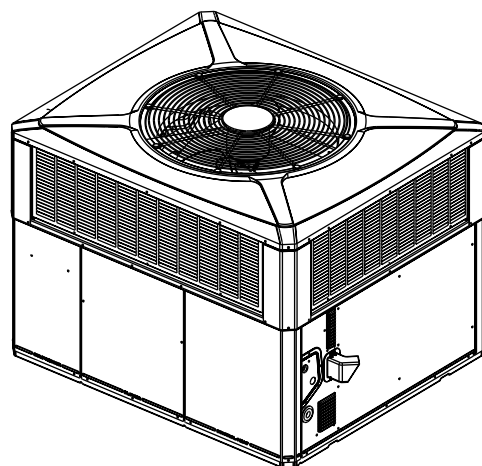

# SAFETY SECTION

**Important** — This document contains a wiring diagram, a parts list, and service information. This is customer property and is to remain with this unit. Please return to service information pack upon completion of work.

## ⚠ WARNING

### HAZARDOUS GASES!

Exposure to fuel substances or by-products of incomplete fuel combustion is believed by the state of California to cause cancer, birth defects, or other reproductive harm.

This warning complies with state of California law, Proposition 65.

## ⚠ WARNING

### HAZARDOUS VOLTAGE!

Failure to follow this Warning could result in property damage, severe personal injury, or death.

Disconnect all electric power, including remote disconnects before servicing. Follow proper lockout/tagout procedures to ensure the power cannot be inadvertently energized.

## ⚠ WARNING

### SAFETY AND ELECTRICAL HAZARD!

Failure to follow this Warning could result in property damage, severe personal injury, or death.

These servicing instructions are for use by qualified personnel only. To reduce the risk of electrical shock, do not perform any servicing other than that contained in these operating instructions unless you are qualified to do so.

## ⚠ CAUTION

### GROUNDING REQUIRED!

Failure to inspect or use proper service tools may result in equipment damage or personal injury. Reconnect all grounding devices. All parts of this product that are capable of conducting electrical current are grounded. If grounding wires, screws, straps, clips, nuts, or washers used to complete a path to ground are removed for service, they must be returned to their original position and properly fastened.

## ⚠ WARNING

### UNIT CONTAINS R-410A REFRIGERANT!

Failure to use proper service tools may result in equipment damage or personal injury. R-410A operating pressure exceeds the limit of R-22. Proper service equipment is required. Service using only R-410A Refrigerant and approved POE compressor oil.

## ⚠ WARNING

### SAFETY HAZARD!

Operating the unit without the access panels properly installed may result in severe personal injury or death.

Do not operate the unit without the evaporator fan access panel or evaporator coil access panel in place.

## ⚠ WARNING

### WARNING!

This product can expose you to chemicals including lead, which are known to the State of California to cause cancer and birth defects or other reproductive harm. For more information go to [www.P65Warnings.ca.gov](http://www.P65Warnings.ca.gov).

**Important:** Wear appropriate gloves, arm sleeve protectors and eye protection when servicing or maintaining this equipment.

**Important:** Air filters and media wheels or plates shall meet the test requirements in UL 900.

# Product Specifications

|   |                 |                 |
|---|-----------------|-----------------|
| <b>MODEL</b>                                      | 4YCC4036A1070A  | 4YCC4036A1090A  |
| RATED Volts/PH/Hz                                 | 208-230/1/60    | 208-230/1/60    |
| Performance Cooling BTUH <sup>(a)</sup>           | 37000           | 37000           |
| Indoor Airflow (CFM)                              | 1190            | 1190            |
| Power Input (KW)                                  | 3.08            | 3.08            |
| EER/SEER (BTU/Watt-Hr.)                           | 12.0 / 14.00    | 12.0 / 14.00    |
| Sound Power Rating [dB(A)] <sup>(b)</sup>         | 69.3            | 69.3            |
| <b>PERFORMANCE HEATING<sup>(c)</sup></b>          |                 |                 |
| Input BTUH-1st Stage (Natural Gas) <sup>(d)</sup> | 70000           | 90000           |
| AFUE  | 81              | 81              |
| Temp. Rise — Min/Max (°F)                         | 30 / 60         | 35 / 65         |
| Orifice Qty/Drill Sz. (Natural Gas)               | 2 / #33         | 3 / #37         |
| <b>POWER CONN. — V/Ph/Hz</b>                      | 208-230/1/60    | 208-230/1/60    |
| Min. Brch. Cir. Ampacity <sup>(e)</sup>           | 24.5            | 24.5            |
| Fuse Size — Max. (amps)                           | 40              | 40              |
| Fuse Size — Recmd. (amps)                         | 40              | 40              |
| <b>COMPRESSOR</b>                                 | SCROLL          | SCROLL          |
| VOLTS/PH/HZ                                       | 208-230/1/60    | 208-230/1/60    |
| R.L. Amps — L.R. Amps                             | 15.4 / 83.9     | 15.4 / 83.9     |
| <b>OUTDOOR COIL — TYPE</b>                        | SPINE-FIN       | SPINE-FIN       |
| Rows/F.P.I  | 2 / 24          | 2 / 24          |
| Face Area (sq. ft.)                               | 15.49           | 15.49           |
| Tube Size (in.)                                   | 3/8             | 3/8             |
| <b>INDOOR COIL — TYPE</b>                         | MCHE            | MCHE            |
| Rows/F.P.I  | 2 / 16          | 2 / 16          |
| Face Area (sq. ft.)                               | 2.7             | 2.7             |
| Tube Size Width (in.)                             | 1               | 1               |
| Refrigeration Control                             | EXPANSION VALVE | EXPANSION VALVE |
| Drain Conn. Size (in.)                            | 3/4 FEMALE NPT  | 3/4 FEMALE NPT  |
| <b>OUTDOOR FAN — TYPE</b>                         | SWEPT           | SWEPT           |
| DIA. (IN.)  | 23.4            | 23.4            |
| DRIVE/NO. SPEEDS                                  | DIRECT / 1      | DIRECT / 1      |
| CFM @ 0.0 in. w.g. <sup>(f)</sup>                 | 3080            | 3080            |
| Motor — HP/R.P.M                                  | 1 / 5 / 825     | 1 / 5 / 825     |

|  |                     |                     |
|--|---------------------|---------------------|
| Volts/Ph/Hz                              | 208-230 / 1 / 60    | 208-230 / 1 / 60    |
| F.L. Amps/L.R Amps                       | 1.1 / 2.0           | 1.1 / 2.0           |
| <b>INDOOR FAN — TYPE</b>                 | CONSTANT TORQUE ECM | CONSTANT TORQUE ECM |
| Dia. x Width (in.)                       | 10.62 X 10.62       | 10.62 X 10.62       |
| Drive/No. Speeds                         | DIRECT-3            | DIRECT-3            |
| CFM @ 0.0 in. w.g. <sup>(g)</sup>        | SEE FAN PERF TABLE  | SEE FAN PERF TABLE  |
| Motor — HP/R.P.M.                        | 1/2 / 1050          | 1/2 / 1050          |
| Volts/Ph/Hz                              | 208-230/1/60        | 208-230/1/60        |
| F.L. Amps                                | 4.1                 | 4.1                 |
| <b>COMBUSTION FAN — TYPE</b>             | CENTRIFUGAL         | CENTRIFUGAL         |
| Drive/No. Speeds                         | DIRECT / 1          | DIRECT / 1          |
| Motor — HP/R.P.M.                        | 1/34 / 3290         | 1/34 / 3075         |
| Volts/Ph/Hz                              | 230/1/60            | 230/1/60            |
| FLA                                      | .20                 | .24                 |
| <b>FILTER / FURNISHED</b>                | NO                  | NO                  |
| Type Recommended                         | THROWAWAY           | THROWAWAY           |
| Recmd. Face Area (sq. ft) <sup>(h)</sup> | 4.0                 | 4.0                 |
| <b>REFRIGERANT</b>                       | R-410               | R-410               |
| Charge (lbs.)                            | 7.2                 | 7.2                 |
| <b>CHARGING SPECIFICATIONS</b>           |                     |                     |
| Subcooling                               | 11°                 | 11°                 |
| <b>GAS PIPE SIZE (in.)</b>               | 1/2                 | 1/2                 |
| <b>DIMENSIONS</b>                        | H X D X W           | H X D X W           |
| Crated (in.)                             | 48 X 45 X 52        | 48 X 45 X 52        |
| <b>WEIGHT</b>                            |                     |                     |
| Shipping (lbs.) / Net (lbs.)             | 438 / 374           | 453 / 379           |

<sup>(a)</sup> Rated in accordance with AHRI Standard 210/240. AHRI standard rating conditions are: 80 D.B.67 W.B. entering air to indoor coil. 95 D. B. entering air to outdoor coil.

<sup>(b)</sup> Sound Power values are not adjusted for AHRI 270-95 tonal corrections.

<sup>(c)</sup> Ratings shown are for elevations up to 2000 ft. For higher elevations reduce ratings at a rate of 4% per 1000 ft. elevation.

<sup>(d)</sup> Convertible to LPG.

<sup>(e)</sup> This value is approximate. For more precise value, see Unit Nameplate.

<sup>(f)</sup> Standard Air — Dry Coil — Outdoor.

<sup>(g)</sup> Based on U.S. Government Standard Tests.

<sup>(h)</sup> Filters must be installed in return air stream. Square footages listed are based on 300 f.p.m. face velocity. If permanent filters are used size per manufacturer's recommendation with a clean resistance of 0.05" W.C.

# Outline Drawings

Figure 1. 4YCC4024-4036

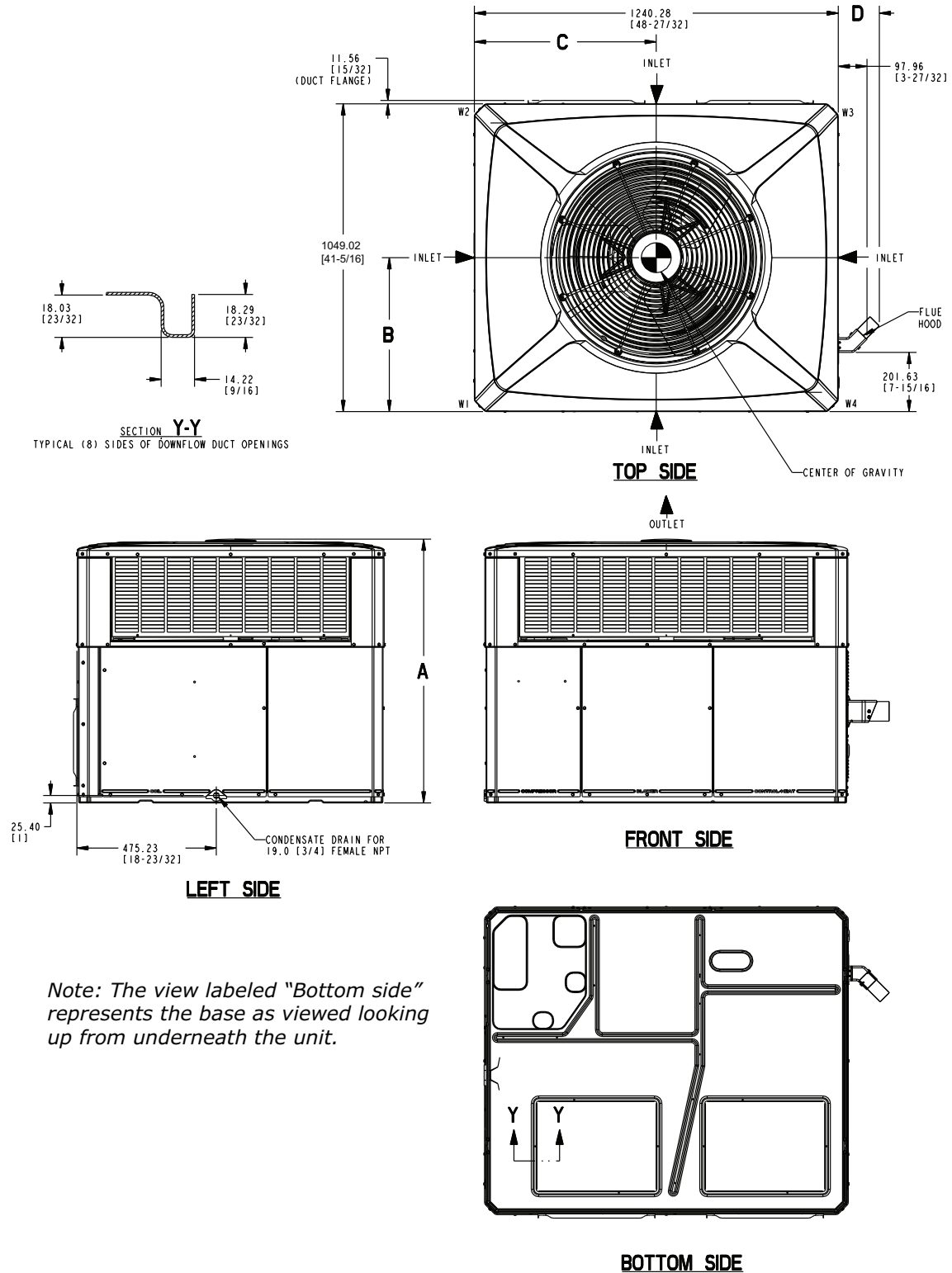

*Note: The view labeled "Bottom side" represents the base as viewed looking up from underneath the unit.*

Figure 2. 4YCC4024-4036

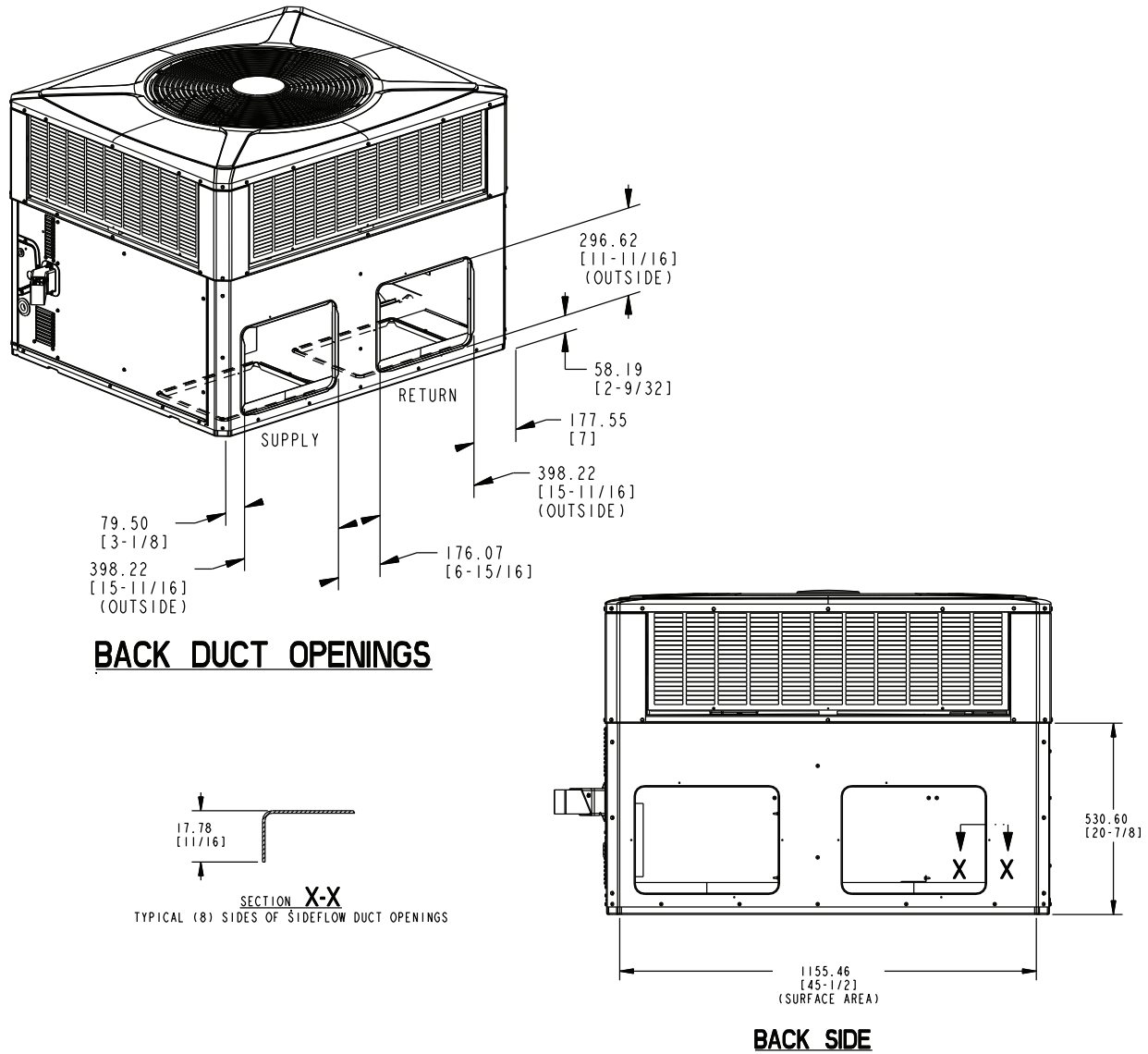

|                | Flu Hood w/brkt<br>mm/in |                 | Approx. Corner Weight - kg / lbs |           |           |           | Shipping<br>Weight<br>kg/lbs | Total Unit<br>Weight<br>kg/lbs | Center of Gravity mm/in |              |
|----------------|--------------------------|-----------------|----------------------------------|-----------|-----------|-----------|------------------------------|--------------------------------|-------------------------|--------------|
|                | A                        | D               | W1                               | W2        | W3        | W4        |                              |                                | B                       | C            |
| 4YCC4024 (060) | 898.53 [35-3/8]          | 157.16 [6-3/16] | 58.3 [129]                       | 36.8 [81] | 26.1 [58] | 41.0 [90] | 196.1 [432]                  | 162.4 [358]                    | 479.8 [18.9]            | 527.8 [20.8] |
| 4YCC4030 (070) | 898.53 [35-3/8]          | 157.16 [6-3/16] | 61.3 [135]                       | 38.7 [85] | 27.5 [61] | 43.1 [95] | 204.8 [451]                  | 171.1 [377]                    | 406.5 [16.0]            | 594.1 [23.4] |
| 4YCC4036 (070) | 949.33 [37-3/8]          | 157.16 [6-3/16] | 61.1 [134]                       | 38.3 [84] | 27.1 [60] | 43.2 [95] | 203.4 [438]                  | 169.7 [374]                    | 414.3 [16.3]            | 697.6 [27.5] |
| 4YCC4036 (090) | 949.53 [37-3/8]          | 157.16 [6-3/16] | 61.7 [136]                       | 38.9 [86] | 27.7 [61] | 43.7 [96] | 205.7 [453]                  | 172.0 [379]                    | 414.3 [16.3]            | 697.6 [27.5] |

Figure 3. 4YCC4024-4036

| RECOMMENDED SERVICE CLEARANCE MM/IN. |             |                 |
|--------------------------------------|-------------|-----------------|
|                                      |             | WITH ECONOMIZER |
| BACK SIDE                            | 304.8 [12]  | 762.0 [30]      |
| LEFT SIDE                            | 762.0 [30]  | 914.4 [36]      |
| RIGHT SIDE                           | 914.4 [36]  | -               |
| FRONT SIDE                           | 1066.8 [42] | -               |

| CLEARANCE TO COMBUSTIBLE MATERIAL MM/IN. |            |
|--|------------|
| BOTTOM                                   | 0          |
| BACK SIDE                                | 25.4 [1]   |
| LEFT SIDE                                | 152.4 [6]  |
| RIGHT SIDE                               | 152.4 [6]  |
| FRONT SIDE                               | 304.8 [12] |
| TOP                                      | 914.4 [36] |

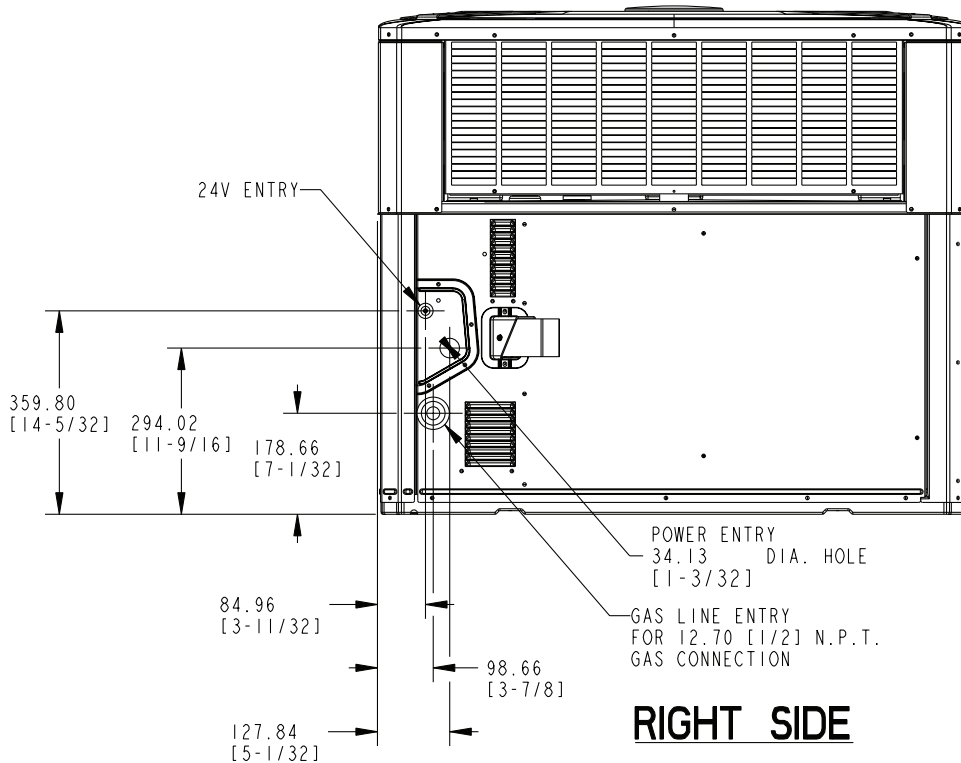
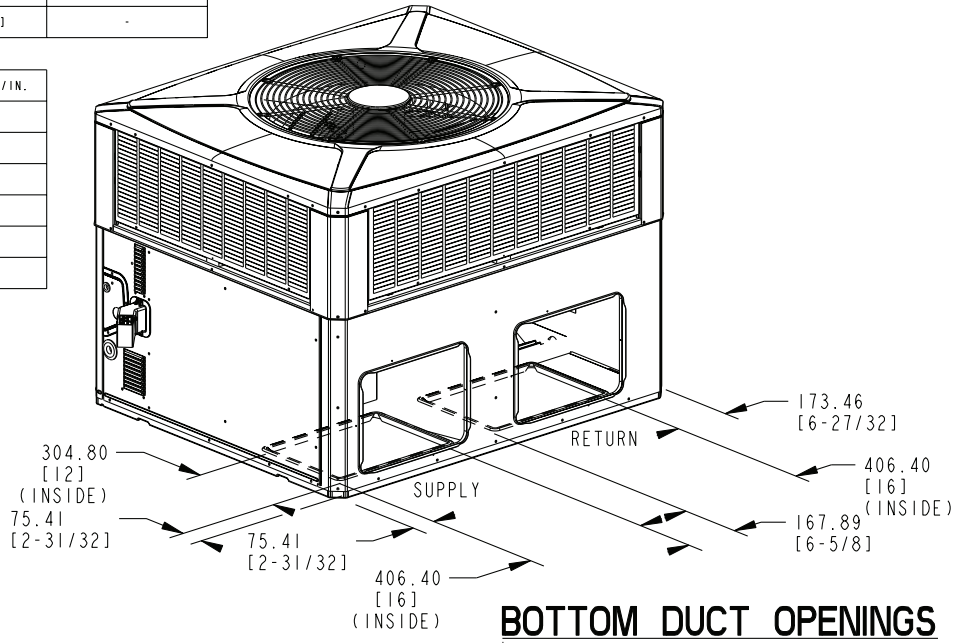

# Indoor Fan Performance

**Table 1. Horizontal Airflow**

| 4YCC4036A1070A       |            |       | EXTERNAL STATIC PRESSURE (IN. WG)                  |      |      |      |      |      |      |      |     |     |     |
|----------------------|------------|-------|--|------|------|------|------|------|------|------|-----|-----|-----|
| MOTOR SPEED          | Tap Number |       | 0  | 0.1  | 0.2  | 0.3  | 0.4  | 0.5  | 0.6  | 0.7  | 0.8 | 0.9 | 1   |
| CONSTANT CIRCULATION | 1          | CFM   | APPROXIMATELY 40 - 50 % COOLING OR HEATING AIRFLOW |      |      |      |      |      |      |      |     |     |     |
|                      |            | WATTS |  |      |      |      |      |      |      |      |     |     |     |
| COOLING-LOW          | 2          | CFM   | 1256   | 1223 | 1193 | 1167 | 1136 | 1101 | 1065 | 1026 | 955 | —   | —   |
|                      |            | WATTS | 339  | 350  | 358  | 366  | 374  | 383  | 391  | 399  | 386 | —   | —   |
| COOLING-HIGH         | 3          | CFM   | 1402   | 1372 | 1344 | 1316 | 1289 | 1241 | 1144 | 1025 | —   | —   | —   |
|                      |            | WATTS | 471  | 479  | 488  | 497  | 506  | 499  | 454  | 406  | —   | —   | —   |
| HEAT-LOW             | 4          | CFM   | 1185   | 1141 | 1099 | 1055 | 1009 | 968  | 920  | 854  | 808 | 731 | 624 |
|                      |            | WATTS | 241  | 251  | 260  | 270  | 279  | 289  | 299  | 311  | 320 | 306 | 284 |
| HEAT-HIGH            | 5          | CFM   | 1386   | 1354 | 1311 | 1276 | 1238 | 1198 | 1164 | 1069 | 805 | 689 | 596 |
|                      |            | WATTS | 386  | 399  | 409  | 419  | 430  | 441  | 452  | 432  | 320 | 303 | 298 |
| 4YCC4036A1090A       |            |       | EXTERNAL STATIC PRESSURE (IN. WG)                  |      |      |      |      |      |      |      |     |     |     |
| CONSTANT CIRCULATION | 1          | CFM   | APPROXIMATELY 40 - 50 % COOLING OR HEATING AIRFLOW |      |      |      |      |      |      |      |     |     |     |
|                      |            | WATTS |  |      |      |      |      |      |      |      |     |     |     |
| COOLING-LOW          | 2          | CFM   | 1288   | 1254 | 1225 | 1193 | 1158 | 1117 | 1070 | 956  | 806 | 639 | —   |
|                      |            | WATTS | 340  | 348  | 357  | 366  | 375  | 385  | 395  | 365  | 320 | 273 | —   |
| COOLING-HIGH         | 3          | CFM   | 1358   | 1326 | 1300 | 1271 | 1241 | 1201 | 1107 | 933  | 739 | 643 | —   |
|                      |            | WATTS | 402  | 410  | 419  | 427  | 437  | 447  | 423  | 361  | 293 | 271 | —   |
| HEAT-LOW             | 4          | CFM   | 1292   | 1259 | 1230 | 1199 | 1163 | 1124 | 1071 | 963  | 799 | 638 | —   |
|                      |            | WATTS | 343  | 351  | 360  | 369  | 378  | 388  | 398  | 370  | 316 | 293 | —   |
| HEAT-HIGH            | 5          | CFM   | 1367   | 1341 | 1310 | 1282 | 1250 | 1212 | 1075 | 928  | 781 | 631 | —   |
|                      |            | WATTS | 404  | 413  | 421  | 431  | 439  | 448  | 404  | 346  | 302 | 282 | —   |

**Table 2. Down Airflow**

| 4YCC4036A1070A       |            |       | EXTERNAL STATIC PRESSURE (IN. WG)                  |      |      |      |      |      |      |      |     |     |     |
|----------------------|------------|-------|--|------|------|------|------|------|------|------|-----|-----|-----|
| MOTOR SPEED          | Tap Number |       | 0  | 0.1  | 0.2  | 0.3  | 0.4  | 0.5  | 0.6  | 0.7  | 0.8 | 0.9 | 1   |
| CONSTANT CIRCULATION | 1          | CFM   | APPROXIMATELY 40 - 50 % COOLING OR HEATING AIRFLOW |      |      |      |      |      |      |      |     |     |     |
|                      |            | WATTS |  |      |      |      |      |      |      |      |     |     |     |
| COOLING-LOW          | 2          | CFM   | 1249   | 1216 | 1185 | 1155 | 1122 | 1089 | 1054 | 1016 | 934 | —   | —   |
|                      |            | WATTS | 343  | 351  | 359  | 367  | 376  | 384  | 392  | 400  | 379 | —   | —   |
| COOLING-HIGH         | 3          | CFM   | 1390   | 1357 | 1329 | 1301 | 1273 | 1212 | 1125 | 1008 | —   | —   | —   |
|                      |            | WATTS | 476  | 485  | 493  | 501  | 508  | 488  | 449  | 398  | —   | —   | —   |
| HEAT-LOW             | 4          | CFM   | 1173   | 1130 | 1088 | 1044 | 999  | 958  | 911  | 846  | 800 | 724 | 618 |
|                      |            | WATTS | 238  | 248  | 258  | 267  | 277  | 286  | 296  | 308  | 316 | 303 | 282 |
| HEAT-HIGH            | 5          | CFM   | 1373   | 1340 | 1298 | 1263 | 1225 | 1186 | 1153 | 1058 | 797 | 682 | 590 |
|                      |            | WATTS | 382  | 395  | 405  | 415  | 425  | 437  | 448  | 428  | 317 | 300 | 295 |
| 4YCC4036A1090A       |            |       | EXTERNAL STATIC PRESSURE (IN. WG)                  |      |      |      |      |      |      |      |     |     |     |

## Indoor Fan Performance

---

**Table 2. Down Airflow (continued)**

| CONSTANT CIRCULATION | 1 | CFM   | APPROXIMATELY 40 - 50 % COOLING OR HEATING AIRFLOW |      |      |      |      |      |      |     |     |   |   |
|----------------------|---|-------|--|------|------|------|------|------|------|-----|-----|---|---|
|                      |   | WATTS |  |      |      |      |      |      |      |     |     |   |   |
| COOLING-LOW          | 2 | CFM   | —  | 1238 | 1207 | 1176 | 1143 | 1091 | 1036 | 928 | 770 | — | — |
|                      |   | WATTS | —  | 348  | 357  | 366  | 375  | 385  | 395  | 365 | 320 | — | — |
| COOLING-HIGH         | 3 | CFM   | 1350   | 1320 | 1294 | 1263 | 1234 | 1196 | 1102 | 928 | 735 | — | — |
|                      |   | WATTS | 402  | 410  | 419  | 427  | 437  | 447  | 423  | 361 | 293 | — | — |
| HEAT-LOW             | 4 | CFM   | 1285   | 1252 | 1222 | 1186 | 1148 | 1111 | 1060 | 954 | 781 | — | — |
|                      |   | WATTS | 343  | 351  | 360  | 369  | 378  | 388  | 398  | 370 | 316 | — | — |
| HEAT-HIGH            | 5 | CFM   | 1355   | 1326 | 1295 | 1267 | 1235 | 1183 | 1056 | 913 | —   | — | — |
|                      |   | WATTS | 404  | 413  | 421  | 431  | 439  | 448  | 404  | 346 | —   | — | — |

# Full Perimeter Roof Mounting Curb

Figure 4. 2.0 – 3.0 Ton Models

## BAYCURB050A Full Perimeter Roof Mounting Curb

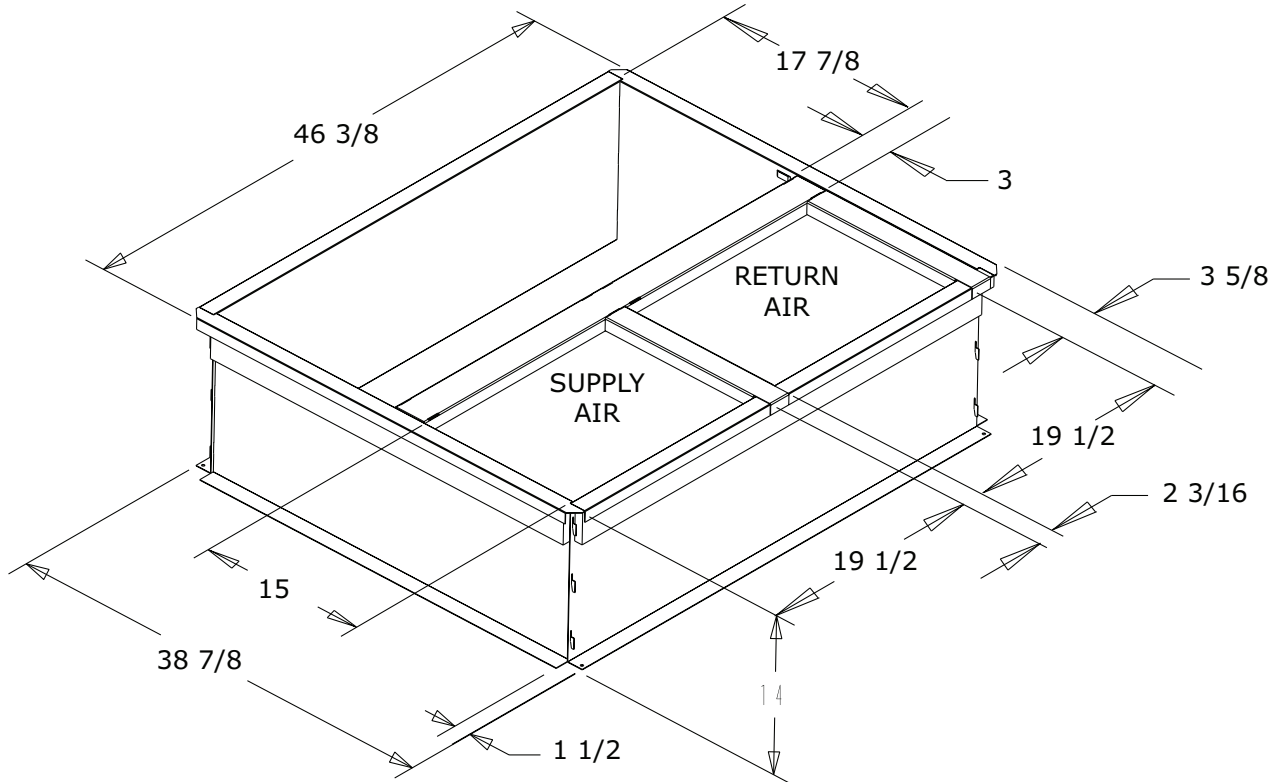

The drawings on this page are prepared by the manufacturer in order to provide detail regarding job layout only. These drawings are not intended to be used as a basis to construct, build or modify the items depicted in the drawings. The manufacturer is not responsible for the unauthorized use of these drawings and expressly disclaims any liability for damages resulting from such unauthorized use.

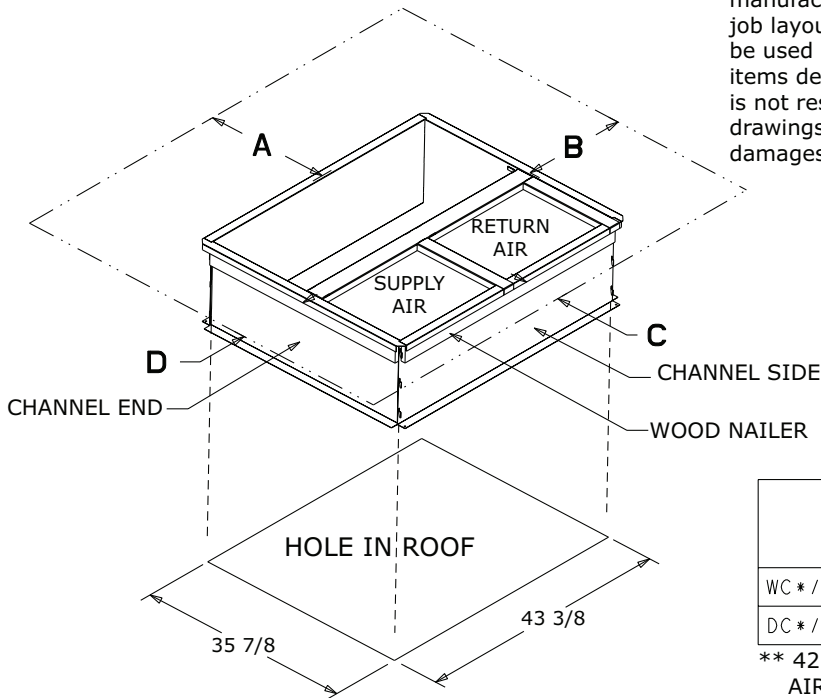

|         | SERVICE CLEARANCE DIMENSIONS |       |         |       |
|---------|------------------------------|-------|---------|-------|
|         | A                            | B     | C       | D     |
| WC*/TC* | 42.00                        | 36.00 | 12.00** | 24.00 |
| DC*/YC* | 42.00                        | 36.00 | 12.00** | 36.00 |

\*\* 42.00 WITH ECONOMIZER WITH 25% FRESH AIR ACCESSORY

# Optional Equipment — Filter Rack

**Figure 5. BAYFLTR101 Filter Rack (2.0 – 3.0 Ton Models)  
BAYFLTR201 (3.5 – 5.0 Ton Models)  
(Mounts in Filter/Coil Section)**

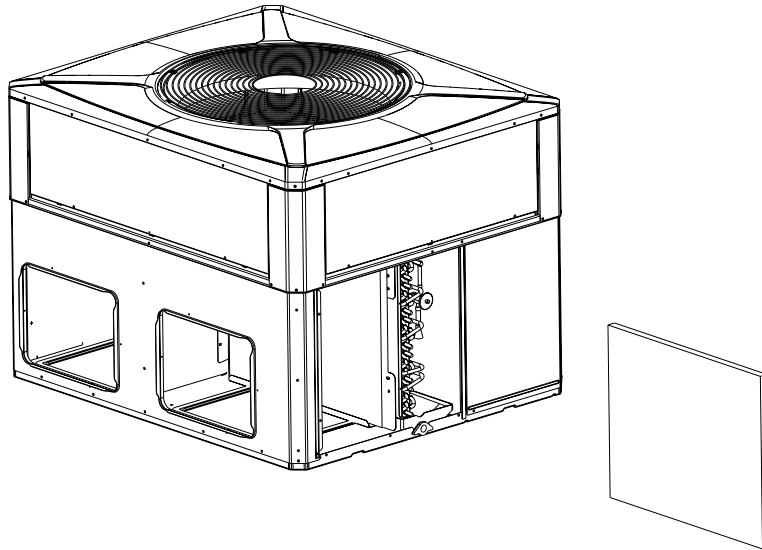

**Figure 6. BAYACCDOR1A Hinged Filter Access Door (2.0 – 3.0 Ton Models)  
BAYACCDOR2A (3.5 – 5.0 Ton Models)  
Replaces Filter/Coil Access Panel**

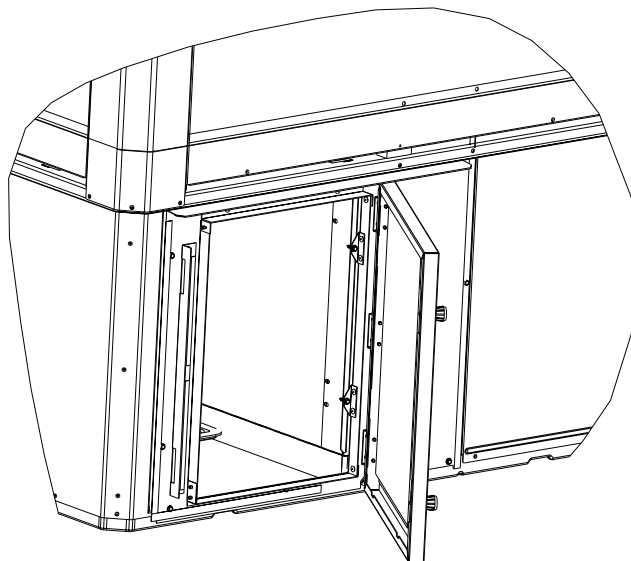

**Note:** The drawings on this page are prepared by the manufacturer in order to provide detail regarding job layout only. These drawings are not intended to be used as a basis to construct, build or modify the items depicted in the drawings. The manufacturer is not responsible for the unauthorized use of these drawings and expressly disclaims any liability for damages resulting from such unauthorized use.

# Optional Equipment – Economizer

**Table 3. BAYECON101,102A Down Discharge Economizer and Rain Hood (Mounts Over Horizontal Return Air Opening)**

|  |                   |                                |
|--|-------------------|--------------------------------|
|  | <b>Economizer</b> | <b>Unit Application Models</b> |
|  | BAYECON101A       | 2.0 – 3.0 Ton Models           |
|  | BAYECON102A       | 3.5 – 5.0 Ton Models           |

**Table 4. BAYCON200, 201A Horizontal Economizer and Rain Hood**

|                   |               |          |           |          |           |           |          |
|-------------------|---------------|----------|-----------|----------|-----------|-----------|----------|
|                   |               |          |           |          |           |           |          |
| <b>Economizer</b> | <b>Models</b> | <b>A</b> | <b>B</b>  | <b>C</b> | <b>D</b>  | <b>E</b>  | <b>F</b> |
| BAYECON200A       | 2.0 – 3.0 Ton | 22"      | 20"       | 16-7/8"  | 15-11/16" | 11-11/16" | 15"      |
| BAYECON201A       | 3.5 – 5.0 Ton | 26"      | 22-21/32" | 19"      | 17-11/16" | 14-11/16" | 21-3/8"  |

**Note:** The drawings on this page are prepared by the manufacturer in order to provide detail regarding job layout only. These drawings are not intended to be used as a basis to construct, build or modify the items depicted in the drawings. The manufacturer is not responsible for the unauthorized use of these drawings and expressly disclaims any liability for damages resulting from such unauthorized use.

# Optional Equipment – Outside Air Damper

**Table 5. BAYOSAH001 and 002A**

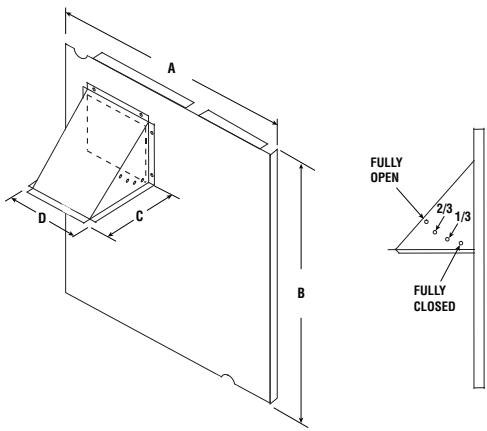

| Manual Fresh Air Model | Unit Application Models | A        | B         | C       | D       |
|------------------------|-------------------------|----------|-----------|---------|---------|
| BAYOSAH001A            | 2.0 – 3.0 Ton           | 22-7/16" | 20-11/16" | 12-3/8" | 9-3/16" |
| BAYOSAH002A            | 3.5 – 5.0 Ton           | 25-3/16" | 20-11/16" | 12-3/8" | 9-3/16" |

**Table 6. BAYDMPR101 and 102A, 25% Motorized Outside Air Damper (Mounts Over Horizontal Return Air Opening)**

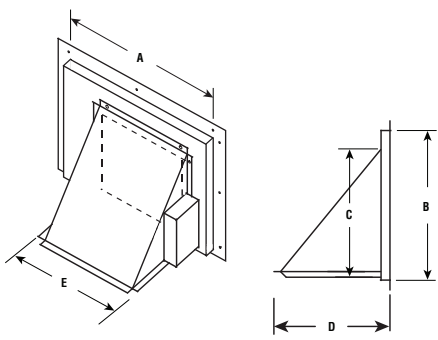

| Manual Fresh Air Model | Unit Application Models | A         | B         | C       | D       | E       |
|------------------------|-------------------------|-----------|-----------|---------|---------|---------|
| BAYDM-PR101A           | 2.0 – 3.0 Ton           | 15-13/16" | 11-13/16" | 10-1/4" | 11-1/2" | 12-1/4" |
| BAYDM-PR102A           | 3.5 – 5.0 Ton           | 18-3/16"  | 15-1/8"   | 10-1/4" | 11-1/2" | 12-1/4" |

**Note:** The drawings on this page are prepared by the manufacturer in order to provide detail regarding job layout only. These drawings are not intended to be used as a basis to construct, build or modify the items depicted in the drawings. The manufacturer is not responsible for the unauthorized use of these drawings and expressly disclaims any liability for damages resulting from such unauthorized use.

# Mechanical Specifications

## General

The units shall be horizontal airflow as shipped and convertible to downflow.

All units shall be factory assembled, piped, internally wired and fully charged with refrigerant. Units shall be certified to UL Standard 1995. Units shall be designed to operate at ambient temperatures as high as 115°F. Cooling performance shall be rated in accordance with AHRI standards. The YC heating/cooling unit design is certified to ANSI 221.47/CSA 2.3, specifically for outdoor applications using natural gas or propane. All units shall be designed for outdoor rooftop or ground level installation.

## Unit Casing

All components shall be mounted in a weather-resistant steel cabinet with an enamel finish. Access panels shall be provided for unit controls and indoor coil and fans. Indoor air section compartment shall be completely insulated with fireproof, permanent, odorless fiber material. Knockouts shall be provided for utility and control connections. Drain connections shall be provided to accommodate indoor water runoff.

## Compressor

The compressor shall be hermetically sealed, high efficiency scroll compressors. Internal overcurrent and over temperature protection, internal pressure relief shall be standard. Other features include centrifugal oil pump, low vibration and noise.

## Refrigeration System

All units shall have refrigerant control. Service pressure tap ports and a refrigerant line filter shall be standard.

**Evaporator Coil (2—4 Ton Models)** All aluminum micro channel, extruded tubes, mechanically bonded to aluminum fins, and factory pressure and leak tested at 480 — 650 psig. All units have TXV to control refrigerant flow.

## Condenser Coil

The Spine Fin™ condenser coil shall be continuously wrapped, corrosion resistant all aluminum with minimum brazed joints. This coil is 3/8" OD seamless aluminum tubing glued to a continuous aluminum fin. Coils are lab tested to withstand 2,000 pounds of pressure per square inch. The outdoor coil provides low airflow resistance and efficient heat transfer. The coil is protected on all four sides by louvered panels.

## Indoor Air Fan

Constant Torque, forward-curved, centrifugal wheel in a Composite Vortica® Blower housing. Motor shall have thermal overload protection and permanently lubricated motor bearings. Motor/blower assembly isolated from unit with rubber mounts.

## Outdoor Fan

One direct-drive, statically and dynamically balanced propeller fan shall be used in a draw-through vertical discharge configuration. Permanently lubricated weather proof motor shall have built-in thermal overload protection.

## System Controls

System controls include condenser fan, evaporator fan and compressor contactors.

## Accessories Roof Curb

The roof curb shall be designed to mate with the unit and provide support and complete weathertight installation when properly installed. Adhesive back polyurethane sealing strips shall be provided to ensure an airtight seal between supply and return openings of the curb and unit. The roof curb design allows field fabricated ductwork to be connected directly to the curb. Curb ships knocked down for field assembly, and includes factory installed wood nailer strips.

## Heating System

### Gas-Fired Heating Section

Models shall provide completely assembled, wired and piped gas fired heating systems within unit. Design certified by UL, specifically for outdoor application. Threaded gas connection on the unit.

### Electric Ignition System

Main burner is lit each time thermostat calls for heat. Flame sensor proves flame and keeps the main burner on. Should a loss of flame occur, the main valve closes and the spark recurs within 0.8 seconds. When thermostat is satisfied, main burner is extinguished.

### Forced Combustion Blower

Insures flame stability under varying wind conditions. Gives higher combustion efficiency and location flexibility.

### Heat Exchanger

Stainless steel tubes. Free floating design.

### Burners

Stainless steel. Multi-port inshot.

## Mechanical Specifications

---

### Single Source Power Entry

This accessory when used with electric heat accessory shall allow single source power connection to unit and heater combination. Single source power entry kits shall have specific matching heater(s). Kit shall include high voltage terminal blocks, fuse blocks and fuses, cut-to-length interconnecting wiring, and junction box (if required) to provide power sources with fuse protection as required for both the unit and accessory heater. Kit components shall install within the heater cabinet in the heater access section. Single source branch power circuit shall be protected and wired in accordance with local codes.

### Fully Modulating Economizer

This accessory shall be field installed and be composed of the following items: 0–100 % fresh air damper, damper drive motor, fixed dry bulb enthalpy control, and low voltage pigtails for electrical connections. Solid state enthalpy or differential enthalpy control is optional. Economizer operations shall be controlled by the preset position of the enthalpy control. A barometric relief damper shall be standard with the economizer and provide a pressure operated damper

that shall be gravity closing and prohibit entrance of outside air on equipment "off" cycle. Economizer requires BAYRLAY004A relay kit to interface the economizer to the heat pump.

### Manual Outside Air Dampers

Rain hood and screen shall be field installed. Suitable for up to 25% outside air.

### Start Kit

Extra compressor starting capacity for single phase equipment.

### Control Options

#### Standard Indoor Thermostats

Two stage heating/cooling or one stage heating/cooling thermostats shall be available in either manual or automatic changeover.

#### Programmable Electronic Night Setting Thermostat

Programmable electronic thermostat shall provide heating setback and cooling setup with 7–day programming capability. 1H/1C or 2H/2C models available.

## About Trane and American Standard Heating and Air Conditioning

Trane and American Standard create comfortable, energy efficient indoor environments for residential applications. For more information, please visit [www.trane.com](http://www.trane.com) or [www.americanstandardair.com](http://www.americanstandardair.com).

---



The AHRI Certified mark indicates company participation in the AHRI Certification program. For verification of individual certified products, go to [ahridirectory.org](http://ahridirectory.org).

The manufacturer has a policy of continuous data improvement and it reserves the right to change design and specifications without notice. We are committed to using environmentally conscious print practices.