

TAG: _____

SUBMITTAL

4 Ton Split System Cooling — 1 Ph

with AccuLink™ and Charge Assist™

4A7Z0048B

Product Specifications

OUTDOOR UNIT ①②	4A7Z0048B1000C
POWER CONNS. — V/PH/HZ ③	200/230/1/60
MIN. BRCH. CIR. AMPACITY	26
BR. CIR. PROT. RTG. - MAX. (AMPS)	40
COMPRESSOR	DURATION™
NO. USED - NO. STAGES	2 - 2
VOLTS/PH/HZ	200/230/1/60
R.L. AMPS ⑦ - L.R. AMPS	18.6 - 93.4
FACTORY INSTALLED	
START COMPONENTS ⑧	YES
INSULATION/SOUND BLANKET	YES
COMPRESSOR HEAT	YES
OUTDOOR FAN	PROPELLER
DIA. (IN.) - NO. USED	27.6 - 1
TYPE DRIVE - NO. SPEEDS	DIRECT - 2
CFM @ 0.0 IN. W.G. ④	4310/3090
NO. MOTORS - HP	1 - 1/3
MOTOR SPEED R.P.M.	760/520
VOLTS/PH/HZ	200/230/1/60
F.L. AMPS	2.80
OUTDOOR COIL — TYPE	SPINE FIN™
ROWS - F.P.I.	2 - 24
FACE AREA (SQ. FT.)	29.15
TUBE SIZE (IN.)	3/8
REFRIGERANT	R-410A
LBS. — R-410 (O.D. UNIT) ⑤	15 LBS.- 7 OZ.
FACTORY SUPPLIED	YES
LINE SIZE - IN. O.D. GAS ⑥	7/8
LINE SIZE - IN. O.D. LIQ. ⑥	3/8
CHARGING SPECIFICATION	See Charging Chart (Service Facts)
SUBCOOLING	
DIMENSIONS	H X W X D
CRATED (IN.)	51 X 35.1 X 38.7
WEIGHT	
SHIPPING (LBS.)	460
NET (LBS.)	410

NOTE: All dimensions are in mm/inches.

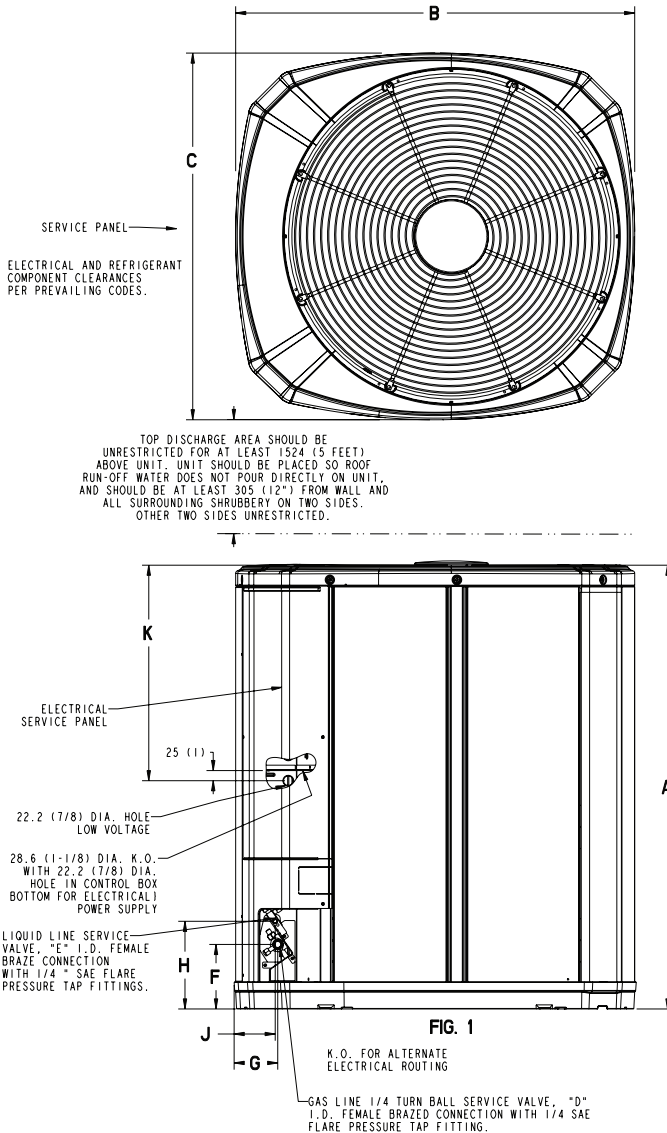

From Dwg. D152862 Rev. 21

MODELS	BASE	A	B	C	D	E	F	G	H	J	K
4A7Z0048B	4	1147 (45 1/8)	946 (37-1/4)	870 (34-1/4)	3/4	3/8	152 (6)	98 (3-7/8)	219 (8-5/8)	86 (3-3/8)	831 (32)

- ① Certified in accordance with the Air-Source Unitary Air-conditioner Equipment certification program, which is based on AHRI standard 210/240. In order to achieve AHRI standard rating, the indoor fan time delay on the comfort control must be enabled.
- ② Rated in accordance with AHRI standard 270.
- ③ Calculated in accordance with Natl. Elec. Codes. Use only HACR circuit breakers or fuses.
- ④ Standard Air — Dry Coil — Outdoor
- ⑤ This value approximate. For more precise value see unit nameplate.
- ⑥ Max. linear length 60 ft.; Max. lift - Suction 25 ft.; Max. lift - Liquid 25 ft. For greater length consult refrigerant piping software Pub. No. 32-3312-0* (* denotes latest revision).
- ⑦ This value shown for compressor RLA on the unit nameplate and on this specification sheet is used to compute minimum branch circuit ampacity and max. fuse size. The value shown is the branch circuit selection current.
- ⑧ No means no start components. Yes means quick start kit components. PTC means positive temperature coefficient starter.

A-weighted Sound Power Level [dB(A)]

MODEL	SOUND POWER LEVEL [dB(A)]		A-WEIGHTED FULL OCTAVE SOUND POWER LEVEL dB - [dB(A)] High Stage							
	Low Stage Overall	High Stage Overall	63	125	250	500	1000	2000	4000	8000
4A7Z0048B1	68	76	51.3	56	68.3	71.3	65.6	69	58.9	49.6

Note: Tested in accordance with ARI Standard 270.95. (Not listed with ARI)

Mechanical Specification Options

General

The 4A7Z0 is fully charged from the factory for matched indoor section and up to 15 feet of piping. This unit is designed to operate at outdoor ambient temperatures as high as 115°F. Cooling capacities are matched with a wide selection of air handlers and furnace coils that are A.R.I. certified. The unit shall be certified to UL 1995. Exterior is designed for outdoor application.

AccuLink™

This outdoor unit contains the AccuLink™ digital communication with 2 wire connection to outdoor and Plug-n-Play set up.

Charge Assist™

The Charge Assist™ indicates system Charge Status.

Casing

Unit casing is constructed of heavy gauge, G60 galvanized steel and painted with a weather-resistant powder paint on all louvers, panels, prepaint on all other panels. Corrosion and weather-proof CMBP-G30 DuraTuff™ base.

Refrigerant Controls

Refrigeration system controls include condenser fan, compressor contactor and high and low pressure switches. High and low pressure controls are inherent to the compressor. A factory installed liquid line drier is standard.

Compressor

Two Duration™ compressors deliver 50% or 100% capacity modulation and feature internal over temperature and pressure protection and total dipped hermetic motor. Other features include: roto lock suction and discharge refrigerant connections, centrifugal oil pump and low vibration and noise.

Condenser Coil

The outdoor coil provides low airflow resistance and efficient heat transfer. The coil is protected on all four sides by louvered panels.

Low Ambient Cooling

As manufactured, this unit has a cooling capability to 55°F. For low ambient cooling below 55° see Application Guide SSC-APG008-EN.

Comfort Control

AccuLink™ Control with Plug-n-Play set up and 3 wire connection.



American Standard
HEATING & AIR CONDITIONING

American Standard Heating & Air Conditioning
www.americanstandardair.com