

Submittal

Side Discharge AC Models

4A7L6036A1000A

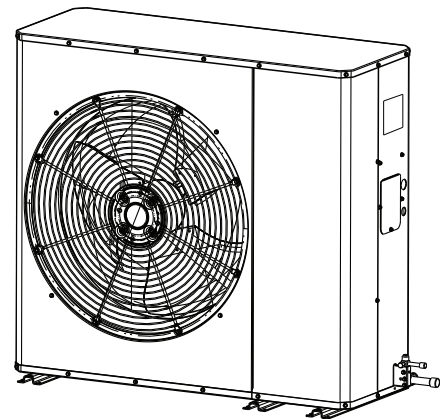

Note: "Graphics in this document are for representation only. Actual model may differ in appearance."

TAG: _____

▲ SAFETY WARNING

Only qualified personnel should install and service the equipment. The installation, starting up, and servicing of heating, ventilating, and air-conditioning equipment can be hazardous and requires specific knowledge and training. Improperly installed, adjusted or altered equipment by an unqualified person could result in death or serious injury. When working on the equipment, observe all precautions in the literature and on the tags, stickers, and labels that are attached to the equipment.

SAFETY SECTION

Important — This document contains service information. This is customer property and is to remain with this unit. Please return to service information pack upon completion of work.

⚠ WARNING

HAZARDOUS VOLTAGE!

Failure to follow this Warning could result in property damage, severe personal injury, or death.

Disconnect all electric power, including remote disconnects before servicing. Follow proper lockout/tagout procedures to ensure the power cannot be inadvertently energized.

⚠ WARNING

REFRIGERANT OIL!

Failure to follow this Warning could result in property damage, severe personal injury, or death.

These units use R-410A refrigerant which operates at 50–70% higher pressures than R-22. Use only R-410A approved service equipment. Refrigerant cylinders are painted a “Rose” color to indicate the type of refrigerant and may contain a “dip” tube to allow for charging of liquid refrigerant into the system. All R-410A systems use a POE oil that readily absorbs moisture from the atmosphere. To limit this “hygroscopic” action, the system should remain sealed whenever possible. If a system has been open to the atmosphere for more than 4 hours, the compressor oil must be replaced. Never break a vacuum with air and always change the driers when opening the system for component replacement. For specific handling concerns with R-410A and POE oil, reference Retrofit Bulletin TRN-APG02-EN.

⚠ CAUTION

HOT SURFACE!

May cause minor to severe burning. Failure to follow this Caution could result in property damage or personal injury.

Do not touch top of compressor.

⚠ CAUTION

CONTAINS REFRIGERANT!

Failure to follow proper procedures can result in personal illness or injury or severe equipment damage.

System contains oil and refrigerant under high pressure. Recover refrigerant to relieve pressure before opening system.

⚠ CAUTION

GROUNDING REQUIRED!

Failure to inspect or use proper service tools may result in equipment damage or personal injury.

Reconnect all grounding devices. All parts of this product that are capable of conducting electrical current are grounded. If grounding wires, screws, straps, clips, nuts, or washers used to complete a path to ground are removed for service, they must be returned to their original position and properly fastened.

⚠ WARNING

SERVICE VALVES!

Failure to follow this warning will result in abrupt release of system charge and may result in personal injury and/or property damage.

Extreme caution should be exercised when opening the Liquid Line Service Valve. Turn valve stem counterclockwise only until the stem contacts the rolled edge. No torque is required.

⚠ WARNING

BRAZING REQUIRED!

Failure to inspect lines or use proper service tools may result in equipment damage or personal injury.

if using existing refrigerant lines make certain that all joints are brazed, not soldered.

Outline Drawing

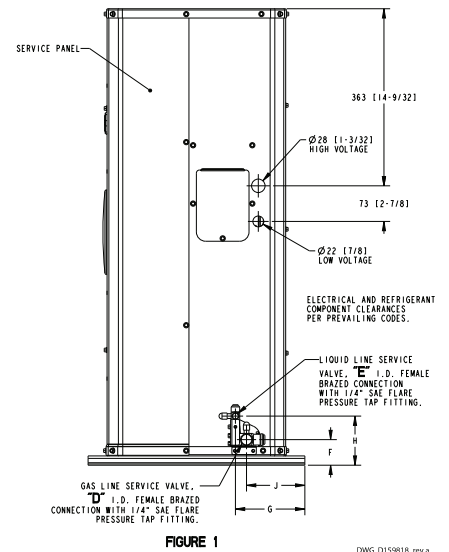
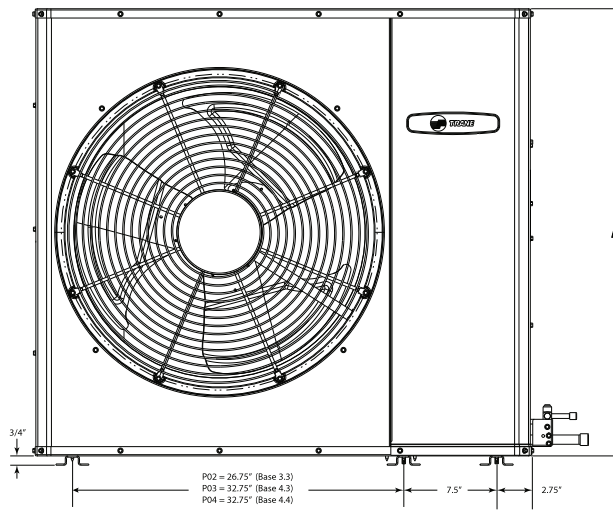
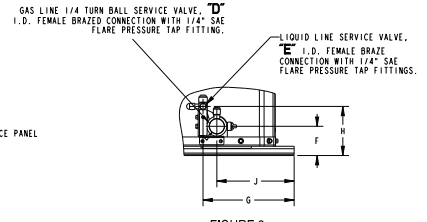
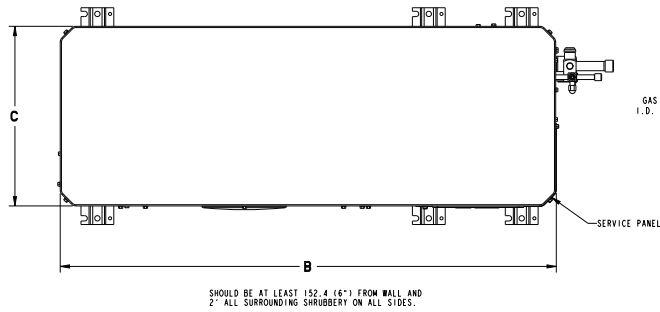

DWG. D159818_Rev A

Model	Base	A	B	C	D	E	F	G	H	J
4A7L6036A	4.3	934 (36-3/4)	1194 (47)	445 (17-1/2)	20 (25/32)	8 (5/16)	53 (2-1/16)	187 (7-11/32)	101 (3-31/32)	159 (6-1/4)

SOUND POWER LEVEL

Model	A-Weighted Sound Power Level [dB(A)]	Full Octave Sound Power [dB]							
		63 Hz*	125 Hz	250 Hz	500 Hz	1000 Hz	2000 Hz	4000 Hz	8000 Hz
4A7L6036A	72	56	76	76	70	66	62	55	48

Note: Rated in accordance with AHRI Standard 270-2008 *For reference only

Product Specifications

OUTDOOR UNIT ^{(a) (b)}	4A7L6036A1000A
HIGH SPEED COOLING CAPACITY@ 80/67-95 (Btuh)	35000
POWER CONNS. — V/PH/HZ ^(c)	208/230/1/60
MIN. BRCH. CIR. AMPACITY	19
BR. CIR. PROT. RTG. — MAX. (AMPS)	30
COMPRESSOR	DURATION®- SCROLL
NO. USED — NO. STAGES	1 — 1
VOLTS/PH/HZ	208/230/1/60
R.L. AMPS ^(d) — L.R. AMPS	14.7 — 75
FACTORY INSTALLED	
START COMPONENTS ^(e)	NO (Uses BAYKSKT263)
INSULATION/SOUND BLANKET	NO
COMPRESSOR HEAT	NO
OUTDOOR FAN	PROPELLER
DIA. (IN.) — NO. USED	27 — 1
TYPE DRIVE — NO. SPEEDS	DIRECT — 1
CFM @ 0.0 IN. W.G. ^(f)	3150
NO. MOTORS — HP	1 — 1/8
MOTOR SPEED R.P.M.	850
VOLTS/PH/HZ	200/230/1/60
F.L. AMPS	0.67
OUTDOOR COIL — TYPE	PLATE FIN
ROWS — F.P.I.	2 — 16
FACE AREA (SQ. FT.)	12.88
TUBE SIZE (IN.)	5/16
REFRIGERANT	
LBS. — R-410A (O.D. UNIT) ^(g)	6 LBS., 7 OZ
FACTORY SUPPLIED	YES
LINE SIZE — IN. O.D. GAS ^(h)	3/4
LINE SIZE — IN. O.D. LIQ.	3/8
CHARGING SPECIFICATIONS	
SUBCOOLING	10°F
DIMENSIONS	H X W X D
CRATED (IN.)	40.88 x 54.5 x 23.0
WEIGHT	
SHIPPING (LBS.)	242
NET (LBS.)	215

(a) Certified in accordance with the Air-Source Unitary Air-conditioner Equipment certification program, which is based on AHRI standard 210/240.

(b) Rated in accordance with AHRI standard 270.

(c) Calculated in accordance with Natl. Elec. Codes. Use only HACR circuit breakers or fuses.

(d) This value shown for compressor RLA on the unit nameplate and on this specification sheet is used to compute minimum branch circuit ampacity and max. fuse size. The value shown is the branch circuit selection current.

(e) No means no start components. Yes means quick start kit components.

(f) Standard Air — Dry Coil — Outdoor

(g) This value approximate. For more precise value see unit nameplate.

(h) Max. linear length 150 ft.; Max. lift — Suction 50 ft.; Max. lift — Liquid 50 ft. For greater length consult refrigerant piping software Pub. No. 32-3312-0* (* denotes latest revision).

Mechanical Specification Options

General

The Outdoor Units are fully charged from the factory for up to 15 feet of piping. This unit is designed to operate at outdoor ambient temperatures as high as 115°F. Cooling capacities are matched with a wide selection of air handlers and furnace coils that are AHRI certified. The unit is certified to UL 1995. Exterior is designed for outdoor application.

Casing

Unit casing is constructed of heavy gauge, galvanized steel and painted with a weather-resistant powder paint finish. The corner panels are prepainted. All panels are subjected to our 1,000 hour salt spray test .

Refrigerant Controls

Refrigeration system controls include condenser fan, compressor contactor and low and high pressure switches. A factory supplied, field installed liquid line drier is standard.

Compressor

The compressor features internal over temperature and pressure protection. Other features include: Centrifugal oil pump and low vibration and noise.

Condenser Coil

The aluminum plate fin, copper tube outdoor coil provides low airflow resistance and efficient heat transfer. The coil is protected with a corrosion resistant mesh coil guard.

Low Ambient Cooling

As manufactured, this system has a cooling capacity to 55°F. The addition of an evaporator defrost control permits operation to 40°F. The addition of an evaporator defrost control with TXV permits low ambient cooling to 30°F.

The addition of the BAYLOAM107A low ambient kit permits ambient cooling to 20°F.

Thermostats—Cooling only and heat/cooling (manual and automatic change over). Sub-base to match thermostat and locking thermostat cover.



Ingersoll Rand (NYSE: IR) advances the quality of life by creating comfortable, sustainable and efficient environments. Our people and our family of brands – including Club Car®, Ingersoll Rand®, Thermo King® and Trane® – work together to enhance the quality and comfort of air in homes and buildings; transport and protect food and perishables; and increase industrial productivity and efficiency. We are a global business committed to a world of sustainable progress and enduring results.



ingersollrand.com

Ingersoll Rand has a policy of continuous product and product data improvements and reserves the right to change design and specifications without notice.
We are committed to using environmentally conscious print practices.