

TAG: \_\_\_\_\_

# Specifications

## 4 Ton Split System Cooling — 1 Phase 4A7A3048A

### Product Specifications

OUTDOOR UNIT ①②	4A7A3048A1000B
<b>POWER CONNS. — V/PH/HZ ③</b>	208/230/1/60
<b>MIN. BRCH. CIR. AMPACITY</b>	27
<b>BR. CIR. PROT. RTG. - MAX. (AMPS)</b>	45
<b>COMPRESSOR</b>	DURATION™ - SCROLL
<b>NO. USED - NO. SPEEDS</b>	1 - 1
<b>VOLTS/PH/HZ</b>	208/230/1/60
<b>R.L. AMPS ⑦ - L.R. AMPS</b>	20.5 - 109
<b>FACTORY INSTALLED</b>	
START COMPONENTS ⑧	NO
INSULATION/SOUND BLANKET	NO
COMPRESSOR HEAT	NO
<b>OUTDOOR FAN</b>	PROPELLER
<b>DIA. (IN.) - NO. USED</b>	27.6 - 1
<b>TYPE DRIVE - NO. SPEEDS</b>	DIRECT - 1
<b>CFM @ 0.0 IN. W.G. ④</b>	4610
<b>NO. MOTORS - HP</b>	1 - 1/4
<b>MOTOR SPEED R.P.M.</b>	825
<b>VOLTS/PH/HZ</b>	200/230/1/60
<b>F.L. AMPS</b>	1.3
<b>OUTDOOR COIL — TYPE</b>	SPINE FIN™
<b>ROWS - F.P.I.</b>	1 - 24
<b>FACE AREA (SQ. FT.)</b>	21.99
<b>TUBE SIZE (IN.)</b>	3/8
<b>REFRIGERANT</b>	
<b>LBS. — R-410 (O.D. UNIT) ⑤</b>	7 LBS., 4 OZ.
<b>FACTORY SUPPLIED</b>	YES
<b>LINE SIZE - IN. O.D. GAS ⑥</b>	7/8
<b>LINE SIZE - IN. O.D. LIQ. ⑥</b>	3/8
<b>CHARGING SPECIFICATION</b>	
<b>SUBCOOLING</b>	10°F
<b>DIMENSIONS</b>	H X W X D
<b>CRATED (IN.)</b>	38.4 x 35.1 x 38.7
<b>WEIGHT</b>	
<b>SHIPPING (LBS.)</b>	251
<b>NET (LBS.)</b>	218

NOTE: All dimensions are in mm/inches.

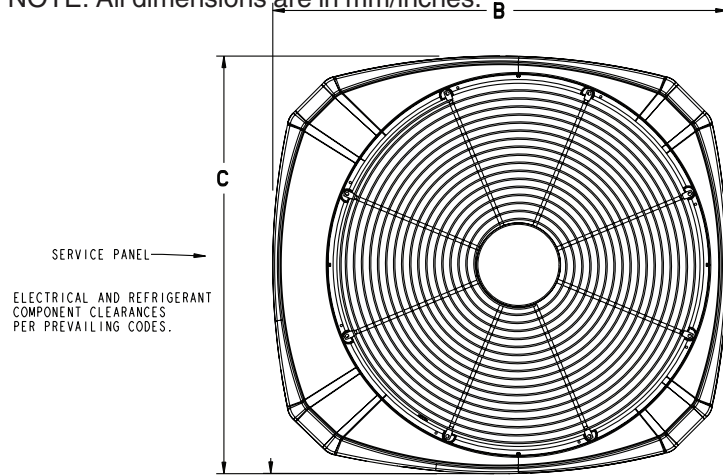

SERVICE PANEL →  
ELECTRICAL AND REFRIGERANT COMPONENT CLEARANCES PER PREVAILING CODES.

TOP DISCHARGE AREA SHOULD BE UNRESTRICTED FOR AT LEAST 1524 (5 FEET) ABOVE UNIT. UNIT SHOULD BE PLACED SO ROOF RUN-OFF WATER DOES NOT POUR DIRECTLY ON UNIT, AND SHOULD BE AT LEAST 305 (12") FROM WALL AND ALL SURROUNDING SHRUBBERY ON TWO SIDES. OTHER TWO SIDES UNRESTRICTED.

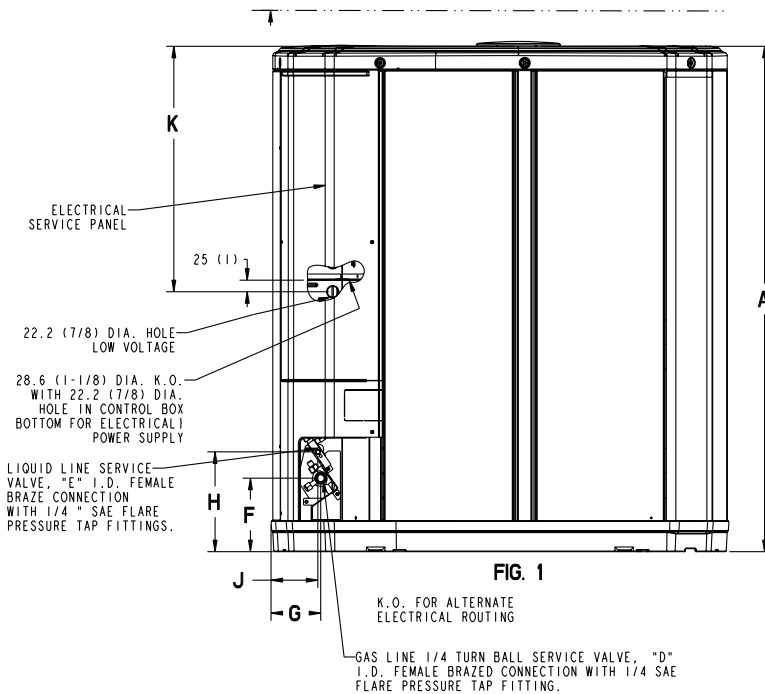

- ① Certified in accordance with the Air-Source Unitary Air-Conditioner Equipment certification program, which is based on ARI standard 210/240.
- ② Rated in accordance with ARI standard 270.
- ③ Calculated in accordance with Natl. Elec. Codes. Use only HACR circuit breakers or fuses.
- ④ Standard Air — Dry Coil — Outdoor
- ⑤ This value approximate. For more precise value see unit nameplate.
- ⑥ Max. linear length 60 ft.; Max. lift - Suction 60 ft.; Max lift - Liquid 60 ft. For greater length consult refrigerant piping software Pub. No. 32-3312-0\* (\* denotes latest revision).
- ⑦ This value shown for compressor RLA on the unit nameplate and on this specification sheet is used to compute minimum branch circuit ampacity and max. fuse size. The value shown is the branch circuit selection current.
- ⑧ No means no start components. Yes means quick start kit components. PTC means positive temperature coefficient starter.

MODELS	BASE	FIG.	A	B	C	D	E	F	G	H	J	K
4A7A3048A	4	1	841 (33-1/8)	946 (37-1/4)	870 (34-1/4)	7/8	3/8	152 (6)	98 (3-7/8)	219 (8-5/8)	86 (3-3/8)	508 (20)

From Dwg. D152862 Rev. 24

### A-weighted Sound Power Level [dB(A)]

MODEL	SOUND POWER LEVEL [dB(A)]	A-WEIGHTED FULL OCTAVE SOUND POWER LEVEL dB - [dB(A)]							
		63	125	250	500	1000	2000	4000	8000
<b>4A7A3048A1</b>	76	55.8	57	62.4	67.5	70.2	67.4	61.1	54.2

Note: Rated in accordance with AHRI Standard 270-2008

# Mechanical Specification Options

---

## General

The 4A7A3 is fully charged from the factory for up to 15 feet of piping. This unit is designed to operate at outdoor ambient temperatures as high as 115°F. Cooling capacities are matched with a wide selection of air handlers and furnace coils that are A.H.R.I. certified. The unit is certified to UL Standard 1995. Exterior is designed for outdoor application.

## Casing

Unit casing is constructed of heavy gauge, G90 galvanized steel and painted with a weather-resistant powder paint on all louvers, panels, prepaint on all other panels. Corrosion and weather-proof CMBP-G30 DuraTuff™ base.

## Refrigerant Controls

Refrigeration system controls include condenser fan, compressor contactor and high pressure switch. High and low pressure controls are inherent to the compressor. A factory installed liquid line drier is standard.

## Compressor

The Climatuff® compressor features internal over temperature and pressure protection and total dipped hermetic motor. Other features include: roto lock suction and discharge refrigerant connections, centrifugal oil pump and low vibration and noise.

## Condenser Coil

The outdoor coil provides low airflow resistance and efficient heat transfer. The coil is protected on all four sides by louvered panels.

## Low Ambient Cooling

As manufactured, this unit has a cooling capability to 55°F. The addition of an evaporator defrost control permits operation to 40° F. The addition of an evaporator defrost control with TXV permits low ambient cooling to 30° F.

## Accessories

**Thermostats** — Cooling only and heat/cooling (manual and automatic changeover). Sub-base to match thermostat and locking thermostat cover.

**Evaporator Defrost Control** — See Low Ambient Cooling.



**ARI Standard  
210/240 UAC**

---

*American Standard*  
HEATING & AIR CONDITIONING

American Standard Heating & Air Conditioning  
6200 Troup Highway  
Tyler, Texas 75711

12/09

The manufacturer has a policy of continuous product and product data improvement **and** it reserves the right to change design and specifications without notice.