

TAG: _____

SUBMITTAL

2 Ton Split System Cooling — 1 Phase

4A7A3024D

Product Specifications

NOTE: All dimensions are in mm/inches.

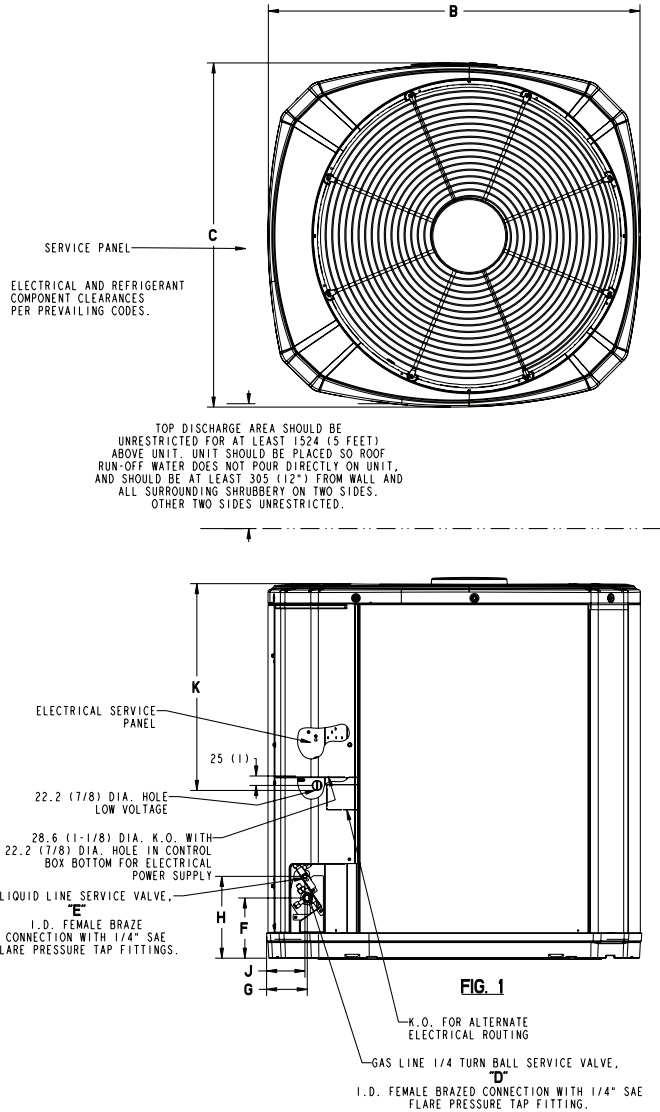

FIG. 1

From Dwg. D152898

OUTDOOR UNIT ^{①②}		4A7A3024D1000A
POWER CONNS. — V/PH/HZ ^③		200/230/1/60
MIN. BRCH. CIR. AMPACITY		11
BR. CIR. PROT. RTG. - MAX. (AMPS)		15
COMPRESSOR		Duration®
NO. USED - NO. SPEEDS		1 - 1
VOLTS/PH/HZ		200/230/1/60
R.L. AMPS ^⑦ - L.R. AMPS		8.3 - 58
FACTORY INSTALLED		
START COMPONENTS ^④		YES
INSULATION/SOUND BLANKET		NO
COMPRESSOR HEAT		NO
OUTDOOR FAN		PROPELLER
DIA. (IN.) - NO. USED		23 - 1
TYPE DRIVE - NO. SPEEDS		DIRECT - 1
CFM @ 0.0 IN. W.G. ^④		2745
NO. MOTORS - HP		1 - 1/8
MOTOR SPEED R.P.M.		825
VOLTS/PH/HZ		200/230/1/60
F.L. AMPS		0.74
OUTDOOR COIL — TYPE		SPINE FIN™
ROWS - F.P.I.		1 - 24
FACE AREA (SQ. FT.)		12.89
TUBE SIZE (IN.)		3/8
REFRIGERANT		
LBS. — R-410A (O.D. UNIT) ^⑤		5 LBS., 8 OZ.
FACTORY SUPPLIED		YES
LINE SIZE - IN. O.D. GAS ^⑥		5/8
LINE SIZE - IN. O.D. LIQ. ^⑥		3/8
CHARGING SPECIFICATION		
SUBCOOLING		10°F
DIMENSIONS		H X W X D
CRATED (IN.)		34 x 30.1 x 33
WEIGHT		
SHIPPING (LBS.)		196
NET (LBS.)		169

- ① Certified in accordance with the Air-Source Unitary Air-conditioner Equipment certification program, which is based on AHRI standard 210/240.
- ② Rated in accordance with AHRI standard 270.
- ③ Calculated in accordance with Natl. Elec. Codes. Use only HACR circuit breakers or fuses.
- ④ Standard Air — Dry Coil — Outdoor
- ⑤ This value approximate. For more precise value see unit nameplate.
- ⑥ Max. linear length 60 ft.; Max. lift - Suction 60 ft.; Max lift - Liquid 60 ft. For greater length consult refrigerant piping software Pub. No. 32-3312-0* (* denotes latest revision).
- ⑦ This value shown for compressor RLA on the unit nameplate and on this specification sheet is used to compute minimum branch circuit ampacity and max. fuse size. The value shown is the branch circuit selection current.
- ⑧ No means no start components. Yes means quick start kit components. PTC means positive temperature coefficient starter.

MODELS	BASE	FIG.	A	B	C	D	E	F	G	H	J	K
4A7A3024D	3	1	730 (28-3/4)	829 (32-5/8)	756 (29-3/4)	5/8	3/8	143 (5-5/8)	92 (3-5/8)	210 (8-1/4)	79 (3-1/8)	508 (20)

A-WEIGHTED SOUND POWER LEVEL [dB(A)]									
MODELS	SOUND POWER LEVEL [dB(A)]	A-WEIGHTED FULL OCTOAVE SOUND POWER LEVEL Db - [dB(A)]							
		63	125	250	500	1000	2000	4000	8000
4A7A3024D	75	79	70	66	69	70	70	62	55

Note: Rated in accordance with AHRI Standard 270-2008

Mechanical Specification Options

General

The 4A7A3 - D model is fully charged from the factory for up to 15 feet of piping. This unit is designed to operate at outdoor ambient temperatures as high as 115°F. Cooling capacities are matched with a wide selection of air handlers and furnace coils that are AHRI certified. The unit is certified to UL 1995. Exterior is designed for outdoor application.

Casing

Unit casing is constructed of heavy gauge, G90 galvanized steel and painted with a weather-resistant powder paint on all louvers, panels, pre-paint on all other panels. Corrosion and weather-proof CMBP-G30 DuraTuff™ base.

Refrigerant Controls

Refrigeration system controls include condenser fan, compressor contactor and high pressure switch. High and low pressure controls are inherent to the compressor. A factory installed liquid line drier is standard.

Compressor

The Duration® compressor features internal over temperature and pressure protection and total dipped hermetic motor. Other features include: roto lock suction and discharge refrigerant connections, centrifugal oil pump and low vibration and noise.

Condenser Coil

The outdoor coil provides low airflow resistance and efficient heat transfer. The coil is protected on all four sides by louvered panels.

Low Ambient Cooling

As manufactured, this unit has a cooling capability to 55°F. The addition of an evaporator defrost control permits operation to 40° F. The addition of an evaporator defrost control with TXV permits low ambient cooling to 30° F.

Accessories

Thermostats — Cooling only and heat/cooling (manual and automatic change-over). Sub-base to match thermostat and locking thermostat cover.

Evaporator Defrost Control — See Low Ambient Cooling.



American Standard
HEATING & AIR CONDITIONING

American Standard
Heating & Air Conditioning
6200 Troup Highway
Tyler, TX 75707
www.americanstandardair.com