

TAG: _____

SPECIFICATION

**Upflow / Horizontal Gas
Furnace "Fan-Assisted
Combustion"**

AUE1A060A9361A

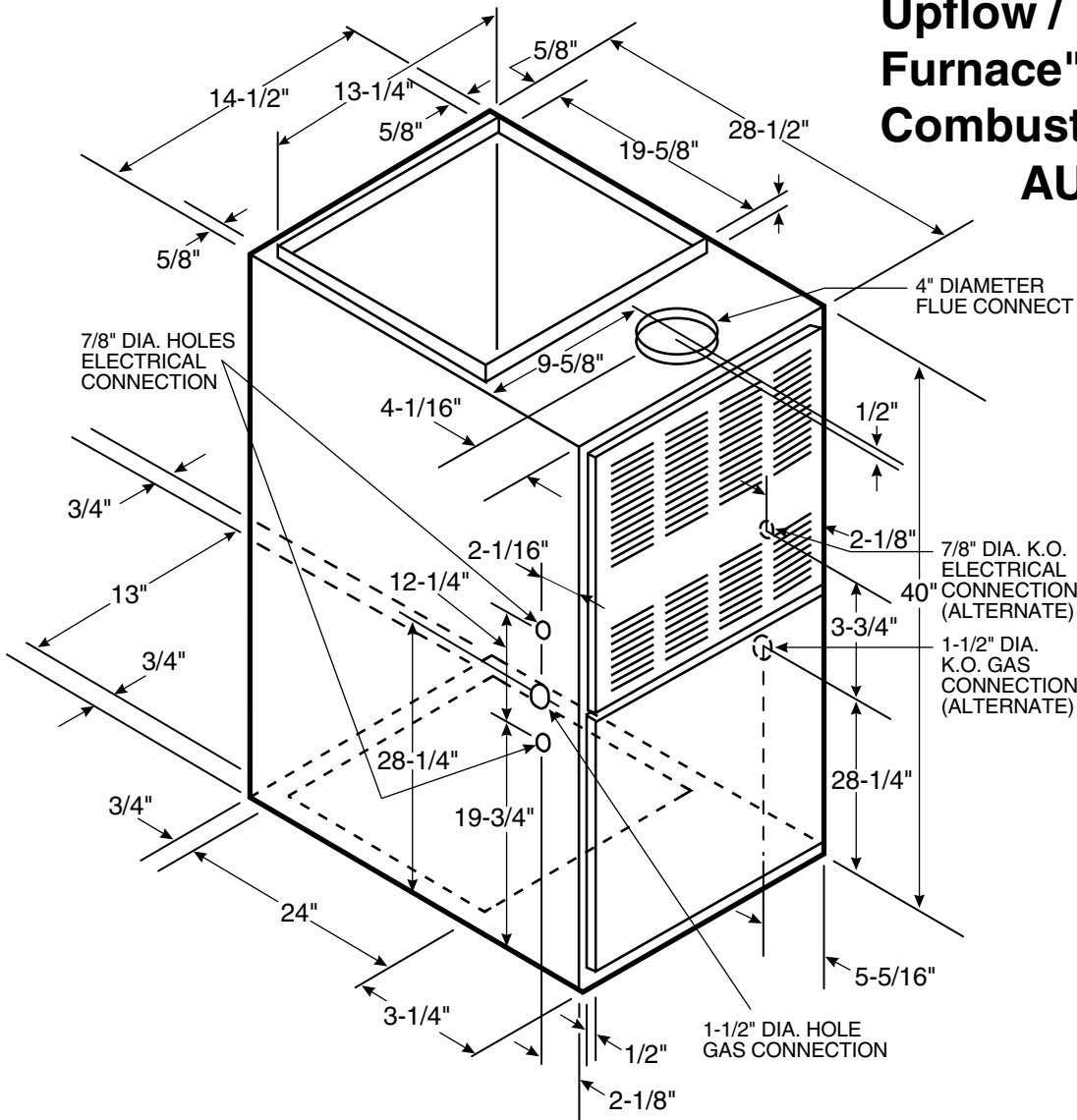

FURNACE AIRFLOW (CFM) VS. EXTERNAL STATIC PRESSURE (IN. W.C.)

MODEL	SPEED TAP	0.10	0.20	0.30	0.40	0.50	0.60	0.70	0.80	0.90
AUE1A060A9361A	4 - HIGH - Black	1426	1389	1345	1298	1236	1171	1099	1020	934
	3 - MED.-HIGH - Blue	1243	1225	1197	1160	1113	1057	991	916	831
	2 - MED.-LOW - Yellow	1042	1039	1027	1005	973	931	879	817	745
	1 - LOW - Red	900	903	895	877	848	809	760	700	629

CFM VS. TEMPERATURE RISE

MODEL	CFM (CUBIC FEET PER MINUTE)						
	800	900	1000	1100	1200	1300	1400
AUE1A060A9361A	56	49	44	40	37	34	32

General Data ①

TYPE	Upflow / Horizontal	VENT COLLAR — Size (in.)	4 Round
RATINGS ②		HEAT EXCHANGER	
Input BTUH	60,000	Type-Fired	Alum. Steel
Capacity BTUH (ICS) ③	47,000	-Unfired	
AFUE	80.0	Gauge (Fired)	20
Temp. rise (Min.-Max.) °F.	30 - 60	ORIFICES — Main	
BLOWER DRIVE	DIRECT	Nat. Gas Qty. — Drill Size	3 — 45
Diameter-Width (In.)	10 x 6	L.P. Gas Qty. — Drill Size	3 — 56
No. Used	1	GAS VALVE	Redundant - Single Stage
Speeds (No.)	4	PILOT SAFETY DEVICE	
CFM vs. in. w.g.	See Fan Performance	Type	Hot Surface Ignition
Motor HP	1/3	BURNERS — Type	Multiport Inshot
R.P.M.	1075	Number	3
Volts/Ph/Hz	115/1/60	POWER CONN. — V/Ph/Hz ④	115/1/60
COMBUSTION FAN - Type	Centrifugal	Ampacity (In Amps)	9.0
Drive - No. Speeds	Direct - 1	Max. Overcurrent Protection (amps)	15
Motor HP - RPM	1/50 - 3180	PIPE CONN. SIZE (IN.)	1/2
Volts/Ph/Hz	115/1/60	DIMENSIONS	H x W x D
F.L. Amps	1.09	Crated (In.)	41- 3/4 x 16-1/2 x 30-1/2
FILTER — Furnished?	No	Uncrated (In.)	40 x 14-1/2 x 28
Type Recommended	High Velocity	WEIGHT	
Hi Vel. (No.-Size-Thk.) Shipped	1 - 16x25 - 1in.	Shipping (Lbs.) / Net (Lbs)	127/ 118

① Central Furnace heating designs are certified to ANSI Z21.47 / CSA 2.3

② Ratings shown are for elevations up to 2000 feet. For elevations above 2000 feet; Ratings should be reduced at the rate of 4% for each 1000 feet above sea level.

③ Based on U.S. Government Standard Tests.

④ The above wiring specifications are in accordance with National Electrical Code; however, installations must comply with local codes.

Mechanical Specifications

NATURAL GAS MODELS — Central heating furnace designs are certified to ANSI Z21.47 / CSA 2.3 for both natural and L.P. gas. Limit setting and rating data were established and approved under standard rating conditions using American National Standards Institute standards.

SAFE OPERATION — The Integrated System Control has solid state devices, which continuously monitor for presence of flame, when the system is in the heating mode of operation. Dual solenoid combination gas valve and regulator provide extra safety.

QUICK HEATING — Durable, cycle tested, heavy gauge **aluminized steel heat exchanger** quickly transfers heat to provide warm conditioned air to the structure. **Low energy power vent blower**, to increase efficiency and provide discharge of gas fumes to the outside, allows common venting with hot water heater.

BURNERS — Multi-port, in-shot burners will give years of quiet and efficient service. All models can be converted to **L.P. gas** without changing burners.

INTEGRATED SYSTEM CONTROL — Exclusively designed operational program provides total control of furnace limit sensors, blowers, gas valve, flame control and includes self diagnostics for ease of service.

AIR DELIVERY — The multispeed, direct-drive blower motor, with sufficient airflow range for most heating and cooling requirements, will switch from heating to cooling speeds on demand from room thermostat. The blower door safety switch will prevent or terminate furnace operation when the blower door is removed. (Fan relay and 35VA control transformer is standard).

STYLING — **Heavy gauge steel and "wraparound" cabinet construction** is used in the cabinet with baked-on enamel finish for strength and beauty. The heat exchanger section of the cabinet is completely lined with foil-faced fiberglass insulation. This results in quiet and efficient operation due to the excellent acoustical and insulating qualities of fiberglass.

FEATURES AND GENERAL OPERATION — These High Efficiency Gas Furnaces employ a Hot Surface Ignition system, which eliminates the waste of a constantly burning pilot. The integrated system control lights the main burners upon a demand for heat from the room thermostat. Complete front service access.

- a. Low energy power venter.
- b. Vent proving differential switch.

American Standard Heating & Air Conditioning has a policy of continuous product and product data improvement and it reserves the right to change specifications and design without notice.

American Standard
Heating & Air Conditioning
6200 Troup Highway
Tyler, TX 75711
www.americanstandardair.com



Library	Unitary
Product Section	Furnaces
Product	Furnace
Model	AUE1
Literature Type	Submittal
Sequence	-
Date	08/09
File No.	AUE1A060-SPEC-2A
Supersedes	AUE1A060-SPEC-2