

pH-TREAT™

PH NEUTRALIZER

NEW

For Neutralizing Condensate from High Efficiency Furnaces, Boilers, and Tankless Water Heaters

- Contains a specialized media that neutralizes the condensate water, raising the pH to near neutral
- 2.5" X 12" cartridge housing with 3/8" FPT connections
- Packaged with two each 1/2" barb fittings x 3/8" MPT fittings
- Packaged with two each 3/4" FPT x 3/8" MPT fittings
- Packaged with 1 each C-clip for mounting
- Designed for gravity feed
- Product life is expected to have a One Year service life, or when the pH falls below 6
- Temperature range 40°F to 100°F
- Pressure range 0-125 psi

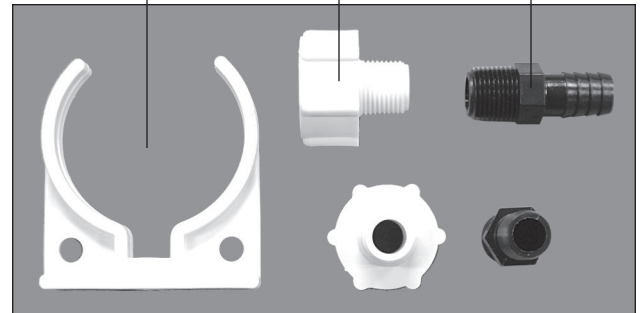

3/8" FPT Connections

Introducing a new in-line treatment product specific for the treatment of the condensate water produced by today's high efficiency furnaces.

The condensate produced by these furnaces is acidic and must be neutralized prior to putting to the drain. In fact, some communities are passing regulations banning the discharge of acidic condensate. Introducing pH-Treat, a product to put on the drain line for the purpose of neutralizing the acid nature of the condensate water produced.

Product Number: 4720-06